

kdl'n

Kdl'n was founded in Milan in 1996. Over twenty-five years of history and the ability to experiment with technology and materials, to anticipate trends and styles. Kdl'n has become a benchmark for the decorative lighting market and its products are sold in more than seventy countries worldwide. Excellent performance, precision in the details and beauty. Every Kdl'n light gives a distinctive and characteristic sign.

Glass, metal, plastic, ceramic are expertly worked by the best manufacturers which the company selects individually to lend shape to its projects. Economic development whilst respecting the environment: this is Kdl'n's main commitment. We are making and will continue to make ecological choices to create the smallest impact, by undertaking responsible and conscious actions for us and for the planet.



SHULAB

MOTUS, ADJUSTABLE SUSPENSION LAMP

Unconditional freedom and ability to adapt to a stimulating environment and changing needs. This is the common denominator between Motus and a skill sport such as vertical wall climbing. Press and Release. A single interaction, a simple movement. Motus slides along its power cord, adjusting to different heights and supporting itself thanks to its own weight.

IT. Libertà incondizionata e capacità di adattarsi all'ambiente, ricco di stimoli ed esigenze mutevoli. Questo è il comune denominatore tra Motus e uno sport di abilità come l'arrampicata su parete verticale. Premi e Rilascia. Un'unica interazione, un semplice movimento. Motus scorre lungo il proprio cavo di alimentazione regolandosi ad altezze diverse e sostenendosi grazie al suo stesso peso.

FR. Une liberté inconditionnelle et la capacité de s'adapter à l'environnement, plein de stimuli et de besoins changeants. C'est le dénominateur commun entre Motus et un sport d'adresse tel que l'escalade de parois verticales. Appuyer et relâcher. Une seule interaction, un mouvement simple. Motus glisse le long de son propre câble d'alimentation, s'ajuste à différentes hauteurs et se soutient grâce à son propre poids.

D. Bedingungslose Freiheit und die Fähigkeit, sich an die Umgebung anzupassen, die voller Reize und wechselnder Bedürfnisse ist. Das ist der gemeinsame Nenner zwischen Motus und einer Geschicklichkeitssportart wie dem Klettern an vertikalen Wänden. Drücken und Loslassen. Eine einzige Interaktion, eine einfache Bewegung. Motus gleitet entlang seines eigenen Stromkabels, stellt sich auf verschiedene Höhen ein und trägt sich selbst durch sein eigenes Gewicht.

ES. Libertad incondicional y capacidad de adaptación al entorno, lleno de estímulos y necesidades cambiantes. Este es el denominador común entre Motus y un deporte de habilidad como la escalada en pared vertical. Presionar y soltar. Una interacción, un simple movimiento. Motus se desliza a lo largo de su propio cable de alimentación, ajustándose a diferentes alturas y sosteniéndose gracias a su propio peso.

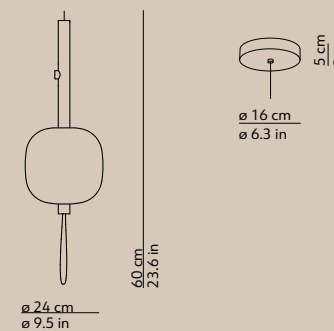

ø 24 x H 60 cm

board LED 1x22W
2700 K - 2420 lm - CRI>90

Dimmable phase cut
Feeding 220-240 / 120 V

IP20 CE

- white RAL9010
- black RAL9005
- red RAL3016





FRANCESCA SMIRAGLIA

IT. Il movimento artistico De Stijl ispira con il suo linearismo e semplicità delle forme. E proprio le forme geometriche bidimensionali come il quadrato e il rettangolo fanno da contrappeso alla luce tubolare e tridimensionale di Model T, la lampada da terra minimalista, scultorea e universale.

FR. Le mouvement artistique De Stijl inspire par son linéarisme et la simplicité de ses formes. Et ce sont précisément les formes géométriques bidimensionnelles telles que le carré et le rectangle qui contrebalancent la lumière tubulaire et tridimensionnelle de Model T, le lampadaire minimaliste, sculptural et universel.

D. Die Kunstrichtung De Stijl inspiriert durch ihre Geradlinigkeit und Einfachheit der Form. Und es sind gerade die zweidimensionalen geometrischen Formen wie das Quadrat und das Rechteck, die ein Gegengewicht zum röhrenförmigen, dreidimensionalen Licht der minimalistischen, skulpturalen und universellen Stehleuchte Model T bilden.

ES. El movimiento artístico De Stijl inspira con su linealismo y simplicidad de formas. Y son precisamente las formas geométricas bidimensionales, como el cuadrado y el rectángulo, las que equilibran la luz tubular y tridimensional de Model T, la lámpara de pie minimalista, escultural y universal.

The De Stijl artistic movement inspires with its linear and simple forms. And precisely, the two-dimensional geometric shapes such as the square and the rectangle act as a counterweight to the tubular and three-dimensional light of Model T, the minimalist, sculptural and universal floor lamp.

MODEL T, FLOOR LAMP

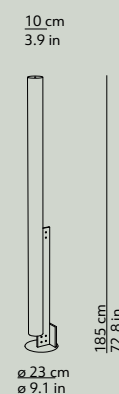

ø 23 x H 185 cm

board LED 1x60W
2700 K - 6600 lm - CRI>90

Dimmer included
Feeding 100-240 V

IP20 CE

- black RAL9005
- pop
- inox

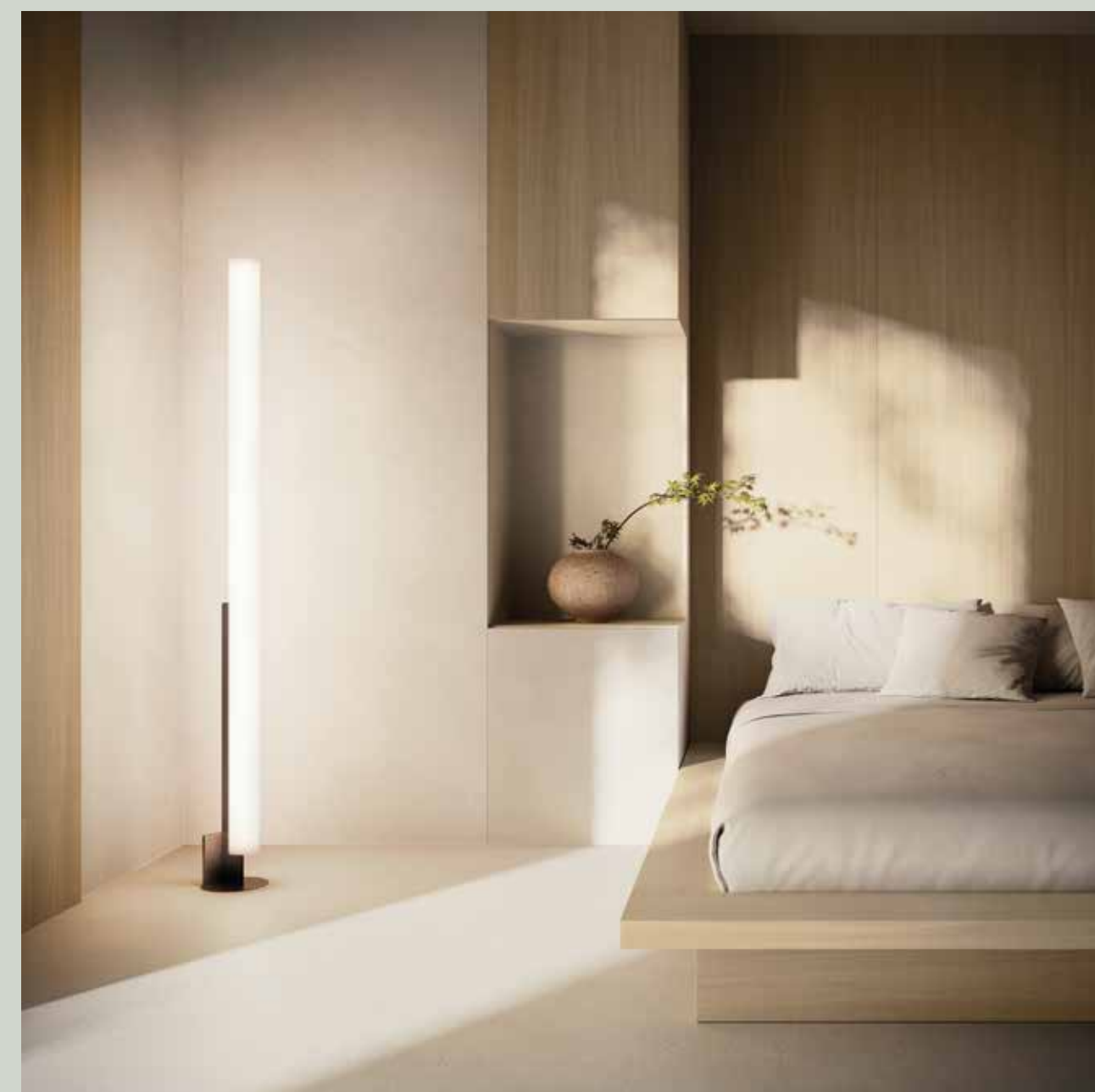

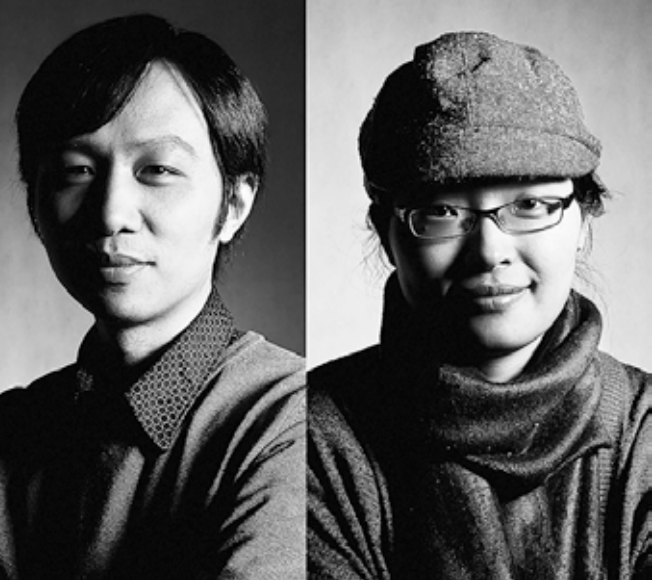

STUDIO SHUU

KOOI, SUSPENSION LAMP

IT. Kooi si ispira alla pittura cinese Shan shui e ne veicola la filosofia. Grazie al contrasto tra il diffusore in vetro e la struttura in metallo a fare da cornice, luci e ombre diventano le protagoniste di continui effetti visivi e inediti cambi di prospettiva. Vetro e metallo. Leggero e pesante. Bianco e nero. Lo spirito Shan shui si fa lampada a sospensione.

FR. Kooi s'inspire de la peinture chinoise Shanshui et en transmet la philosophie. Grâce au contraste entre le diffuseur en verre et le cadre métallique, l'ombre et la lumière deviennent les protagonistes d'effets visuels continus et de changements de perspective sans précédent. Verre et métal. Léger et lourd. Noir et blanc. L'esprit Shanshui devient une lampe suspendue.

D. Kooi ist von der chinesischen Shan-Shui-Malerei inspiriert und vermittelt deren Philosophie. Dank des Kontrasts zwischen dem Glasdiffusor und dem Metallrahmen werden Licht und Schatten zu Protagonisten kontinuierlicher visueller Effekte und noch nie dagewesener Perspektivwechsel. Glas und Metall. Leicht und schwer. Schwarz und Weiß. Der Geist von Shan Shui wird zu einer Hängeleuchte.

ES. Kooi se inspira en la pintura china Shan shui y transmite su filosofía. Gracias al contraste entre el difusor de cristal y el marco de metal, la luz y la sombra se convierten en protagonistas de continuos efectos visuales y cambios de perspectiva originales. Cristal y metal. Luz y peso. Blanco y negro. El espíritu Shan shui se convierte en una lámpara colgante.

Kooi is inspired by Chinese Shan shui painting and conveys its philosophy. Thanks to the contrast between the glass diffuser and the metal frame, lights and shadows become the protagonists of continuous visual effects and unprecedented changes of perspective. Glass and metal. Light and heavy. Black and white. The Shan shui spirit becomes a suspension lamp.

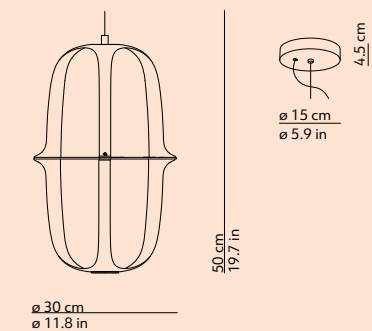
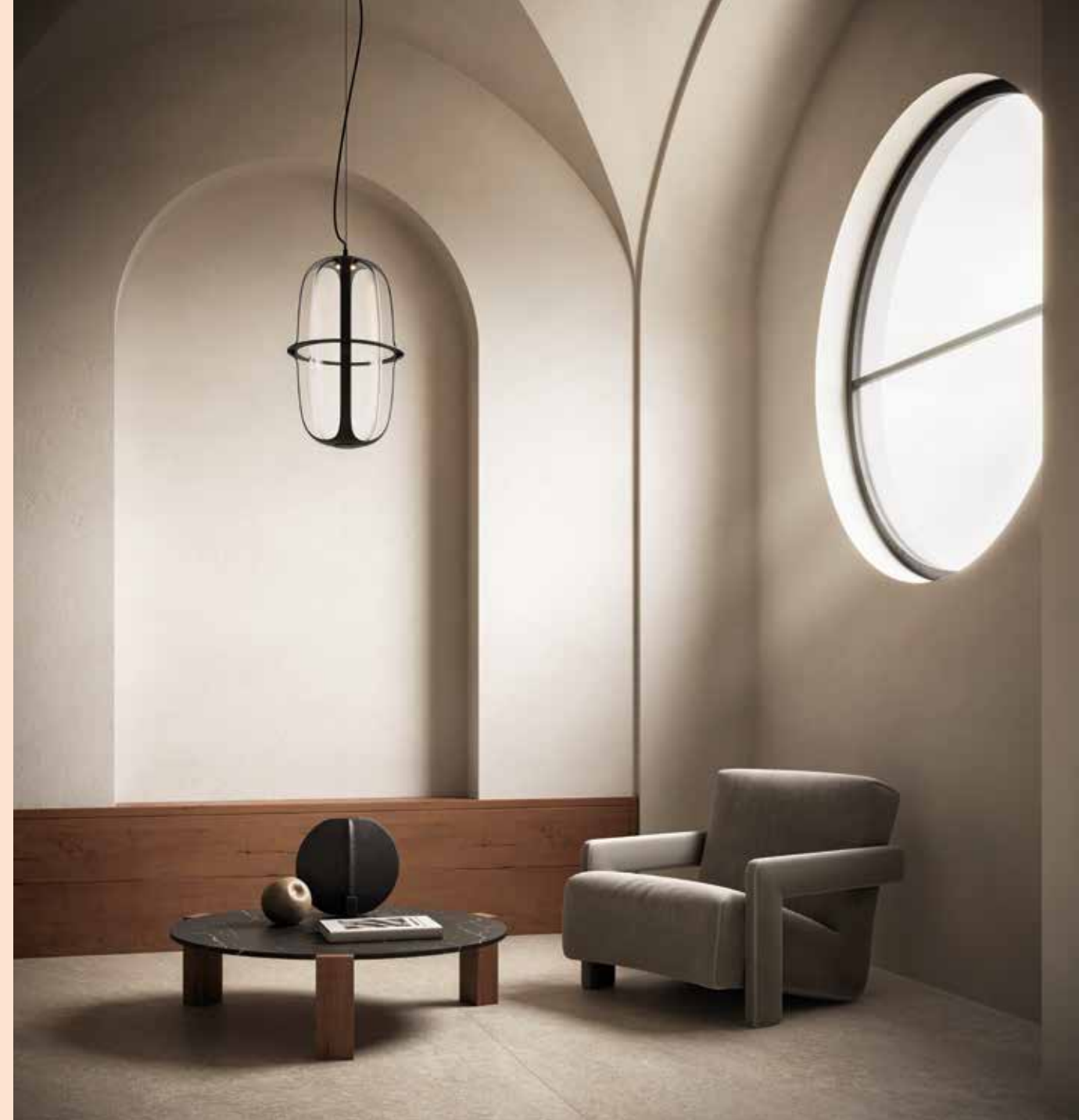

ø 30 x H 50 cm

board LED 1x25W
2700 K - 2750 lm - CRI>90

Dimmable phase cut
Feeding 220-240 / 120 V

© IP20 CE

● black RAL9005

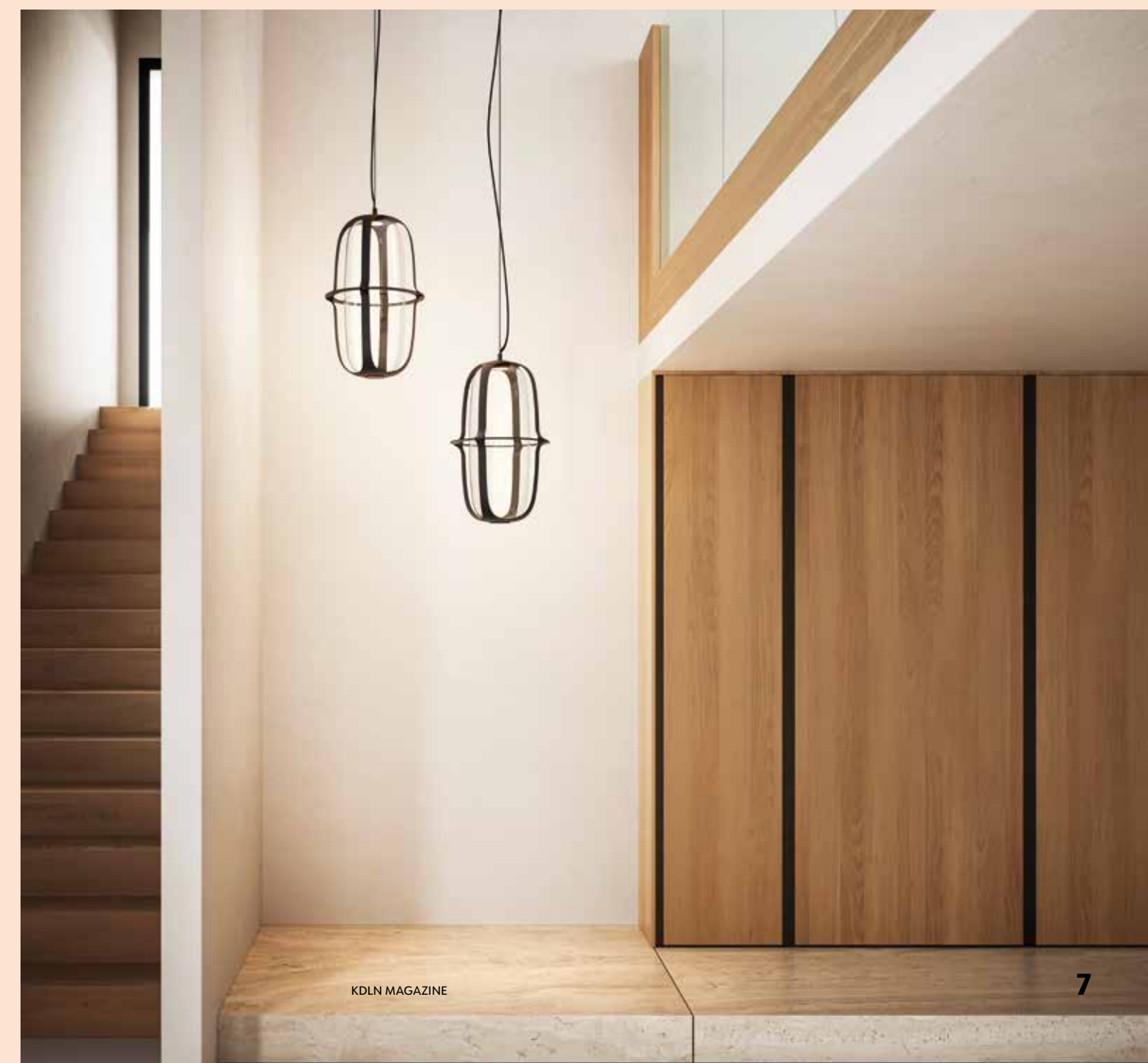



CHRIS BASIAS

IT. Un unico cavo unipolare trasferisce la corrente e supporta sorgenti luminose multiple. Come una fionda all'aria aperta, questo cavo proietta installazioni di luce, dando vita a geometrie spettacolari e configurazioni sempre inaspettate. Direttamente dalla nostra infanzia, Sling gioca con semplicità e infinite variabili.

FR. Un seul câble unipolaire transfère le courant et supporte plusieurs sources lumineuses. Comme une fronde à l'air libre, ce câble projette des installations lumineuses, créant des géométries spectaculaires et des configurations toujours inattendues. Tout droit sorti de notre enfance, Sling joue avec la simplicité et les variables infinies.

D. Ein einziges unipolares Kabel überträgt Strom und unterstützt mehrere Lichtquellen. Wie eine Schleuder im Freien projiziert dieses Kabel Lichtinstallationen, die spektakuläre Geometrien und immer wieder unerwartete Konfigurationen schaffen. Direkt aus unserer Kindheit spielt Sling mit Einfachheit und unendlichen Variablen.

ES. Un único cable unipolar transfiere corriente y soporta múltiples fuentes de luz. Como un tirachinas al aire libre, este cable proyecta instalaciones de luz, creando geometrías espectaculares y configuraciones siempre inesperadas. Directamente desde nuestra infancia, Sling juega con la simplicidad y las variables infinitas.

SLING, SUSPEN- SION LAMP

A single unipolar cable transfers current and supports multiple light sources. Like a slingshot in the open air, this cable projects light installations, giving life to spectacular geometries and configurations that are always unexpected. Straight from our childhood, Sling plays with simplicity and endless variables.

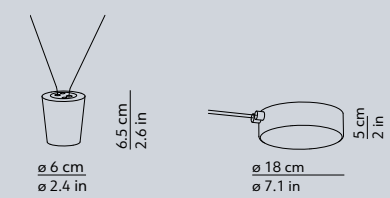

ø 6 x H 6.5 cm

board LED 1x6W
3000 K - 660 lm - CRI>90

Dimmable 1-10V or push
Feeding 220-240 / 120 V

◇ IP20 C €

● black RAL9005

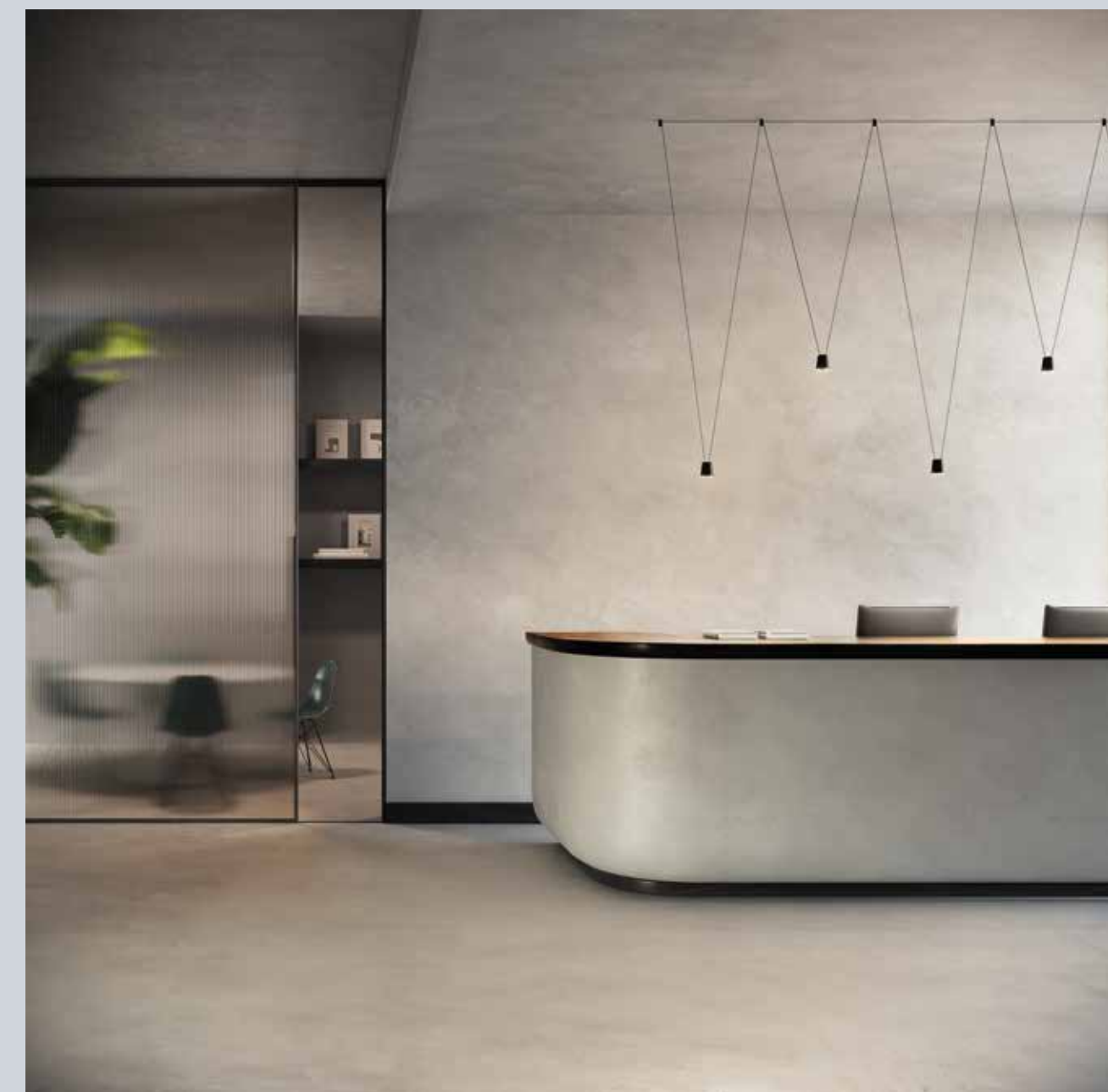



FRANCESCA SMIRAGLIA

Architectural forms and unconventional dimensions. The headgear worn by the Duchess of Cambridge for the 70th anniversary of the English jubilee inspires Kate, the ceiling light that rewrites the perceptual rules of space. This conical lamp is positioned on the ceiling with an inclination of 15 degrees in order to diffuse the light in an unexpected way.

KATE, CEILING LAMP

IT. Forme architettoniche e dimensioni non convenzionali.

Il copricapo sfoggiato dalla duchessa di Cambridge per i 70 anni del giubileo inglese, ispira Kate, la plafoniera che riscrive le regole percettive dello spazio. Questa lampada dalla forma conica è posizionata a soffitto con un'inclinazione di 15 gradi in modo da diffondere la luce in maniera inaspettata.

FR. Des formes architecturales et dimensions non conventionnelles. La coiffe portée par la duchesse de Cambridge pour le 70e anniversaire du Jubilé britannique a inspiré Kate, le plafonnier qui réécrit les règles de perception de l'espace. Cette lampe en forme de cône est positionnée au plafond avec un angle de 15 degrés afin de diffuser la lumière de manière inattendue.

D. Architektonische Formen und unkonventionelle Dimensionen.

Der Kopfschmuck, den die Herzogin von Cambridge zum 70. Jahrestag des britischen Thronjubiläums trug, inspirierte Kate, die Deckenleuchte, die die Wahrnehmungsregeln des Raums neu schreibt. Die kegelförmige Leuchte ist in einem Winkel von 15 Grad an der Decke angebracht, um das Licht auf unerwartete Weise zu streuen.

ES. Formas arquitectónicas y dimensiones no convencionales.

El tocado que lució la Duquesa de Cambridge en el 70º aniversario del Jubileo Británico, ha sido la fuente de inspiración de Kate, la lámpara de techo que reescribe las reglas perceptivas del espacio. Esta lámpara de forma cónica se coloca en el techo con un ángulo de 15 grados para difundir la luz de forma inesperada.

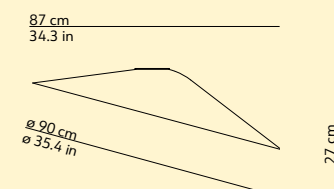

ø 90 x L 87 x H 27 cm

KATE 2700 K
board LED 1X60W
2700 K - 6600 lm - CRI>90

KATE 3000 K
board LED 1X60W
3000 K - 6835 lm - CRI>90

Dimmable phase cut
Feeding 220-240 / 120 V

Ⓜ IP20 CE

- white RAL9010
- custom colours on request

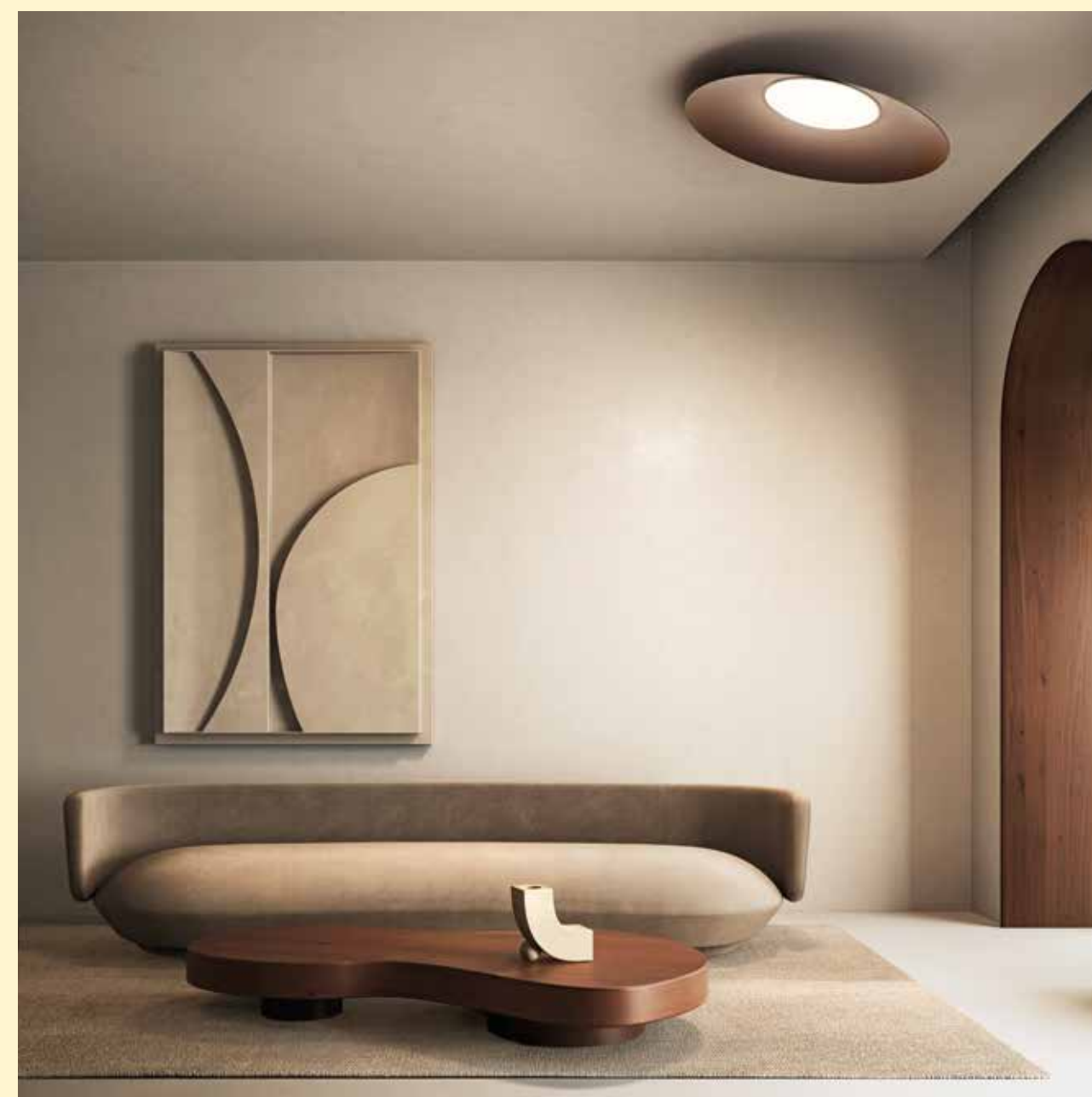
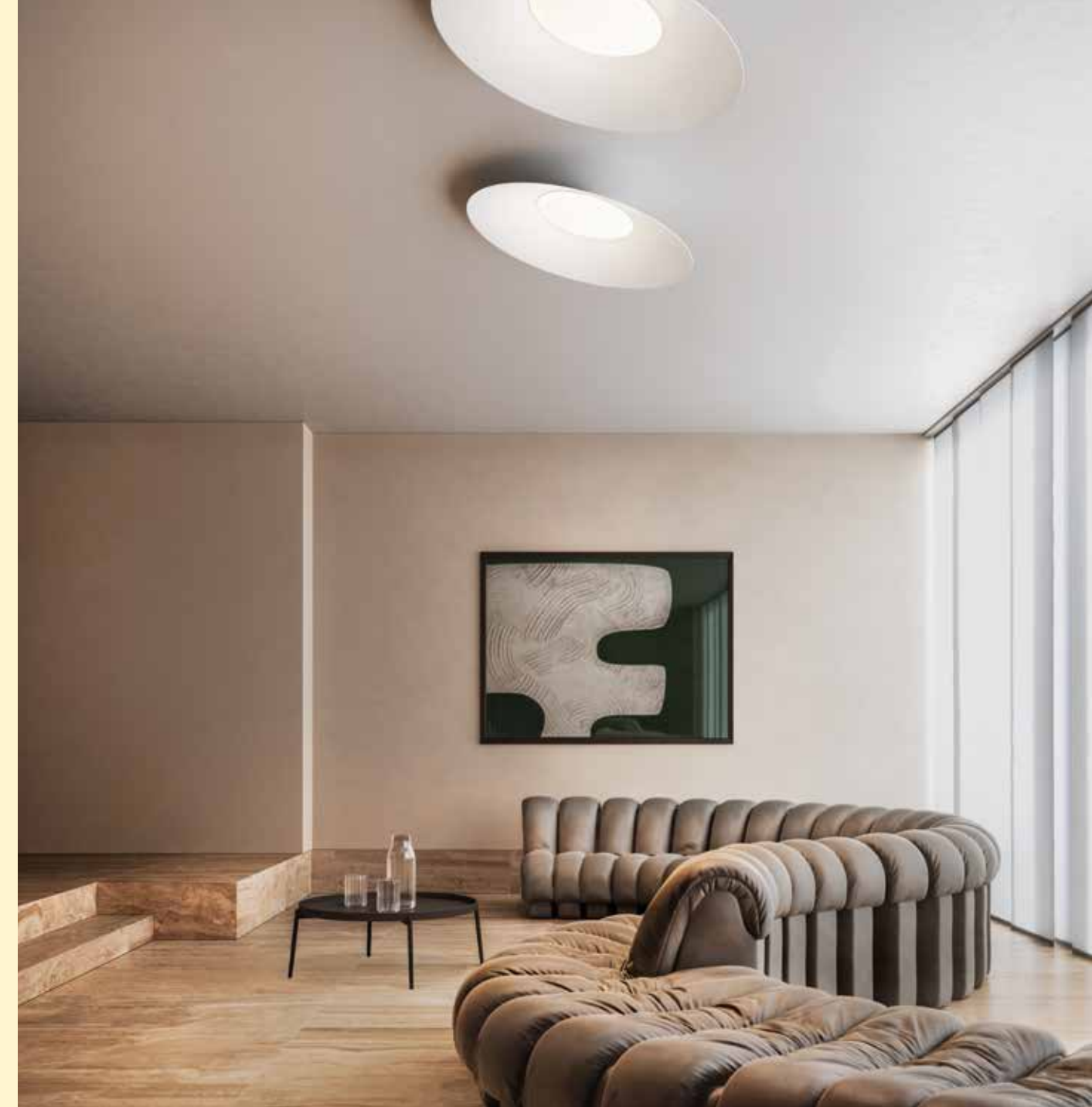



MITOS • Chris Basias



POISE FLOOR • Robert Dabi



FLOW CEILING • Chris Basias



DALA • Francesca Smiraglia



POISE • Robert Dabi

H I G H L I G H T S

EN. Light is poetry and beauty, functionality and technique, simplicity and character. A universal language, a unique and versatile style, that draws on the past in an interpretation that is original and contemporary.

IT. La luce è poesia e bellezza, funzionalità e tecnica, semplicità e carattere. Un linguaggio universale, uno stile unico e versatile, che attinge al passato in una lettura originale e contemporanea.

FR. La lumière est poésie et beauté, fonctionnalité et technique, simplicité et caractère. Un langage universel, un style unique et polyvalent, qui puise dans le passé dans une lecture originale et contemporaine.

D. Licht ist Poesie und Schönheit, Funktionalität und Technik, Schlichtheit und Charakter. Eine universelle Sprache, ein einzigartiger und vielseitiger Stil, der sich in einer originellen und zeitgenössischen Interpretation auf die Vergangenheit stützt.

ES. La luz es poesía y belleza, funcionalidad y técnica, simplicidad y carácter. Un lenguaje universal, un estilo único y versátil, que recurre al pasado en una lectura original y contemporánea.



POISE CEILING • Robert Dabi



FLOW • Chris Basias



KYUDO • Hansandfranz

VICEVERSA • Noé Duchaufour Lawrance



DALA LINEAR • Francesca Smiraglia



AZOU • Chris Basias



NAMI • Alberto Saggia & Valerio Sommella



EVITA • Aquilalberg



KUSHI FLOOR • Alberto Saggia & Valerio Sommella



KUSHI XL TABLE • Alberto Saggia & Valerio Sommella



LILLI • Cristina Celestino



DEW • Emmanuel Babled



KUSHI CEILING • Alberto Saggia & Valerio Sommella



GIASS • Sebastian Herkner



LANNÄ TABLE • Noé Duchaufour Lawrance



KUSHI XL FLOOR • Alberto Saggia & Valerio Sommella



KUSHI TABLE • Alberto Saggia & Valerio Sommella



LANNÄ SUSPENSION • Noé Duchaufour Lawrance



OPYO FLOOR • Cristina Celestino



TATU • Mrsmith Studio



OPYO SUSPENSION • Cristina Celestino



KUSHI SUSPENSION • Alberto Saggia & Valerio Sommella



JER • Valerio Sommella & Anonima Luci



discover more



CONCEPT & GRAPHIC PROJECT

VZNstudio

Printed in Italy

Industrie Grafiche Pacini, April 2023

Kdln is a registered trademark

Copyright © 2023 Kdln Srl

All Rights Reserved.

Reproduction in whole or in part of texts and images
without express written permission is prohibited.